

FAQs for Using Lithium-ion Batteries with a UPS

White Paper 231

Revision 0

by Patrick Donovan
Martin Zacho

Executive summary

Lithium-ion batteries offer several advantages over traditional lead acid batteries. Despite the benefits, the use of lithium-ion batteries in uninterruptable power supplies (UPSs or battery backups) is relatively new with valve-regulated lead acid batteries still the dominant energy storage technology used today. This will likely change as Li-ion costs continue to decrease, the benefits become more widely known, and manufacturers make their UPSs compatible. This paper serves to answer common questions about Li-ion batteries and their use in UPSs.

Introduction

Lithium-ion batteries offer several advantages over traditional valve-regulated, lead acid batteries commonly used in UPSs today. A much longer life span, smaller size and weight, faster recharge times, and declining prices have made lithium-ion batteries an appealing energy storage technology. This paper serves to briefly answer common questions about lithium-ion batteries and their use in UPS applications to aid the user in making a decision as to which battery technology is best for their battery backup needs.

FAQs

What is a lithium-ion battery and how does it differ from a lead-acid battery?

In the simplest of terms, a battery is an electro-chemical device that stores energy and releases it as electricity. Batteries are typically organized in strings and can be connected in series, in parallel, or a combination of both to achieve whatever voltage and current is required for a given application. This simple description applies to both lead acid and lithium-ion batteries.

Every battery contains a cathode (positive) and an anode (negative) that are suspended in an electrolyte. Electrolyte acts as a catalyst for the electrochemical reaction which results in charging and discharging as ions flow from one electrode to the other. It also prevents electrons built up on the anode from flowing back to the cathode within the battery itself when no load is attached. The chemical reaction results in a potential difference in charge (i.e., voltage) between the cathode and anode as electrons build up on the anode. By connecting a load with a wire to the battery's terminals, current flow is induced which discharges the battery as electrons flow (i.e., current) from the anode (negative terminal) to the load and then to the cathode (positive terminal). The chemistry of the battery changes as this ion flow occurs until no more electrons can be supplied to the anode which results in a discharged battery. The battery can be recharged by using an external power source to reverse the flow of electrons through the electrolyte from the cathode to the anode. **Figure 1**¹ shows a simple diagram of the flow of electrons within the battery and between it and the load.

Figure 1

Diagram showing the flow of electrons through the components of a battery; applies to both lead acid and lithium-ion batteries

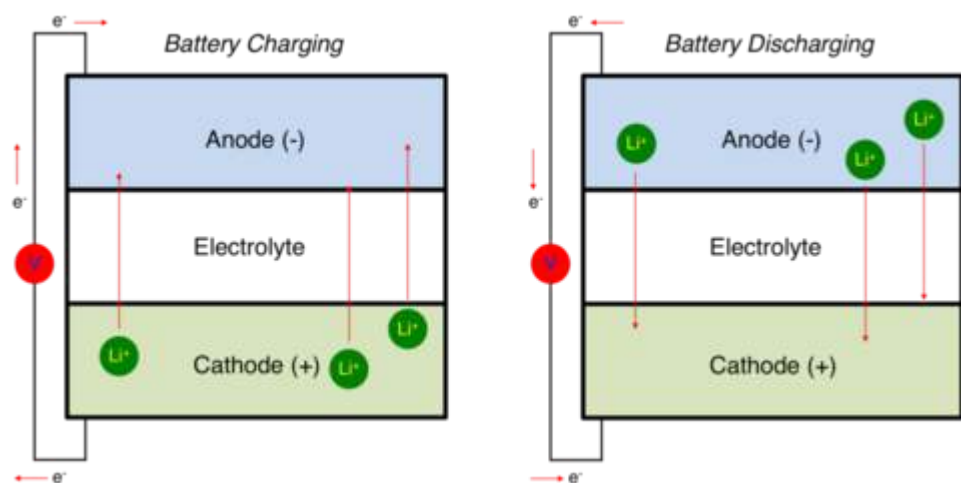

¹ <http://batterybro.com/blogs/18650-wholesale-battery-reviews/18880255-battery-chemistry-finally-explained> (last accessed on 2/26/16)

So, the principle difference between a lithium-ion battery and a lead-acid is the chemical makeup of the materials used in the electrodes and electrolyte. Most current lithium-ion batteries use a metal oxide for the cathode and a carbon-based material for the anode. The electrolyte solution is a lithium salt dissolved in an organic solvent. A lead-acid battery, on the other hand, uses a lead dioxide for the cathode, a lead anode, and a form of sulfuric acid as the electrolyte.

This chemistry determines, to a large extent, the battery's performance capabilities. **Table 1** highlights some of the high level performance differences between the two types of batteries as used in UPS applications. However, it is important to understand that there can be a lot of variability in performance between one battery and another *of the same type* due to differences in chemistry (i.e., composition of electrolyte and electrodes) and the overall type and quality of the materials used, as well as the cell construction. This makes generalizing or summarizing lithium-ion battery characteristics difficult unless a specific application and design is assumed. This table shows typical performance ranges for the kind of battery cells being used in UPSs today.

Table 1

Typical performance ranges for lithium-ion battery cells being used in UPS applications

Performance attribute	Lithium-ion	Lead-acid (VRLA)
Specific energy (Energy density)	High, 70 - 260 kWh/kg	Low, 15 - 50 kWh/kg
Life span (calendar)	10 - 15 years	4 - 6 years
# of charge/discharge cycles*	>1,000	200-400
Recharge time	½ - 1 hr	6 - 12 hours

* The actual # is highly dependent on the specific battery design and the depth of the discharges. The deeper the discharges, the lower the cycle life will be.

How do the costs of Lithium-ion battery systems compare to lead-acid battery systems when used with a UPS?

White Paper 229, [Battery Technology for Data Centers: VRLA vs. Li-ion](#) provides a detailed quantitative analysis of capital costs, operating expenses, and a 10 year TCO for batteries in a 3-phase UPS used in a data center application. In general, however, it can be said that the installed cost of a Li-ion system costs roughly 1.5 to 3 times more (as of 2016) than what it would cost for a valve-regulated lead acid battery system at the same power level and runtime. The initial purchase price has been the principal reason why the use of Lithium-ion batteries in UPSs has been so very limited. However, it's worth noting that only a few years ago that cost difference was 10X. With the cost down so much combined with strong performance advantages, Li-ion-based systems are increasingly becoming a viable energy storage option for more and more people. Increasing demand, future technology enhancements, and additional gains in manufacturing efficiency will likely lead to further cost reductions. Lead-acid batteries, on the other hand, are an older, more mature technology with less of a chance of significant evolution occurring that would materially change the cost per kWhr much further downwards.

On the operating expense (OPEX) side, the Li-ion system has a clear advantage. This is mostly due to the life span being roughly double (or more) than VRLA systems. Over a 15 year period, VRLAs would likely have to be replaced 2-3 times whereas Li-ion might not need any replacements (or possibly once) saving significant money and reducing the amount of maintenance. Li-ion battery cycle life is

sometimes specified at a higher temperature (40°C/104°F) than lead acid (20-25°C/68-77°F). So, in these cases, they can tolerate a higher ambient temperature and still meet its specified cycle life². This could allow additional OPEX savings by reducing cooling energy. And because lithium-ion battery systems are 50-80% smaller, this re-claimed space could be put to more productive use. The financial value of that could further improve the total cost of ownership of Lithium-ion systems. Our analysis has shown that, in general, Li-ion-based UPS systems have a TCO that is 10-40% less (as of 2016) than that of a VRLA system over a 10 year period.

Are lithium-ion batteries a safety hazard?

All battery types, by definition, store chemical energy, so every battery if mishandled (e.g., thrown in a fire) or overcharged has the potential for being a hazard by releasing hazardous materials or igniting a fire. Lithium-ion batteries have been thought to be more volatile due to reported cases of fire and due to their much higher specific energy combined with a greater sensitivity to being over charged. Improperly managed, a lithium-ion battery will reach a “thermal runaway” state more easily as it has a lower cell resistance and higher energy storage capacity than a lead acid battery.

However, much progress has been made over the years making them safer and much more comparable safety-wise to other commonly used battery types. Chemistry changes and cell packaging improvements have made them more stable. Manufacturing processes are mature and the materials used are more durable. Battery management schemes are well tested and field proven to keep lithium-ion batteries from being over charged or over heated. The prolific use of lithium batteries in hundreds of millions of portable electronics, smart phones, and electric vehicles is positive evidence for their level of safety.

Because lithium-ion battery systems are much more sensitive to how they are charged and discharged, all include a battery management system, or BMS. Microprocessors, sensors, switches, and their related circuits make up this system. It constantly monitors at the cell level battery temperature, charge level, and charge rate to protect against short circuits and overcharging. The system is also instrumental in protecting the cells from damage by preventing the voltage from going too low on discharge. The BMS provides the UPS and user with accurate information about battery status, health, and available runtime. Although the BMS makes lithium-ion battery systems much safer, they do come at a cost. They add cost to the solution and drain energy from the batteries eliminating or greatly reducing the efficiency advantages they offer compared to lead acid.

As to whether the battery materials are hazardous, the US Government considers them not to be hazardous and, therefore, is safe for disposal in landfills. Li-ion batteries do not contain mercury, lead, cadmium, or any other material deemed to be hazardous. Of course, this does not mean that recycling, or a lack of recycling, does not have an environmental impact. See the FAQs, “Are lithium-ion batteries ‘greener’ than lead acid?” and “Are they recyclable?” below to learn more.

² Note that runtime might be reduced when operating at higher temperatures due to internal protection schemes designed to prevent thermal runaway conditions.

What are the different types of lithium-ion batteries and why does it matter?

All Lithium-ion batteries today use a non-metallic solution containing lithium-ions as the electrolyte. This solution is the conductor of electrons that results in current flow between the two electrodes, the (+) cathode and anode (-). The cathode is a metal oxide while the anode is made of a porous carbon material. The performance characteristics will change as these materials change or are modified chemically. Manufacturers substitute materials and/or use additives to affect how a particular cell performs. Some batteries, for example, are engineered to maximize energy capacity and allow long runtime measured in hours. These are often referred to as “energy cells”. “Power cells” on the other hand, are tweaked to offer very high power densities (i.e. specific power), but with lower energy capacity where all of its power can be supplied to the load in a short period of time. Because UPS systems tend to be configured to expend their batteries in a short period of time (minutes), power cells are used. In this way, batteries are engineered for their intended application. And new chemistries are being formulated and tested to further push the limits of today’s lithium-ion battery technology.

A common way to differentiate types of Li-ion batteries is based on their main active chemical material that gives the battery its unique, intrinsic attributes relative to other Li-ion batteries. According to Battery University³, six of the more common types are:

- **Lithium Cobalt Oxide (LiCoO₂)**
- **Lithium Manganese Oxide (LiMn₂O₄ or “LMO”)**
- **Lithium Nickel Manganese Cobalt Oxide (LiNiMnCoO₂ or “NMC”)**
- **Lithium Iron Phosphate (LiFePO₄)**
- **Lithium Nickel Cobalt Aluminum Oxide (LiNiCoAlO₂)**
- **Lithium Titanate (Li₄Ti₅O₁₂)**

Table 2 shows how the different chemistry types vary from one to another in terms of their key attributes.

Table 2

Shows how the different chemistry types vary from one another in terms of their key attributes

Chemistry Type	Specific Energy	Specific Power	Safety*	Performance	Lifespan	Cost
LiCoO ₂ (LCO)	highest	moderate	moderate	high	moderate	moderate
LiMn ₂ O ₄ (LMO)	high	high	high	moderate	moderate	moderate
LiNiMnCoO ₂ (NMC)	highest	high	high	high	high	moderate
LiFePO ₄ (LFP)	moderate	highest	highest	high	highest	moderate
LiNiCoAlO ₂ (NCA)	highest	high	moderate	high	high	high
Li ₄ Ti ₅ O ₁₂ (LTO)	moderate	high	highest	highest	highest	highest

* Safety refers to how resistant the chemistry is naturally to entering an uncontrolled state or “thermal runaway” situation. Note that the choice of materials, cell packaging, manufacturing quality, and the battery management system can be designed to ensure such a condition does not occur despite a given chemistry’s propensity to go into a thermal runaway condition or not.

³ http://batteryuniversity.com/learn/article/types_of_lithium_ion (last accessed on 2/26/16)

There are other aspects besides chemistry that differentiate one battery from another. Individual battery cells can be packaged in different ways and this has an effect on the performance of the battery. There are prismatic pouches and cans, as well as cylindrical cans (see **Figure 2**). How the cells are packaged along with the type and quality of materials used in their construction impacts the battery in terms of weight, energy density, ability to conduct heat, durability (safety), and price.

Figure 2

3 common ways to package a lithium-ion cell (left to right): prismatic pouch, prismatic can, and cylindrical can



You should not assume one lithium-ion battery is the same as another...even when the chemistry is the same. UPS manufacturers should choose the cell design and material quality level appropriate for the intended application. And they should make their specific battery system's characteristics and performance specs openly available to the public.

Can I use lithium-ion batteries with my existing UPS?

Only if the UPS manufacturer says that the specific Li-ion battery in question is compatible. As explained above, Lithium-based batteries come in many different chemistries, sizes, voltage ranges, form factors, and connector types. These differences must be accounted for in the UPS inverter, charger, mechanical, and firmware design implementation. That being said, assuming the voltage of the battery system is within the range of the capabilities of the UPS, it is possible that an existing UPS could be made compatible through an update of the UPS's firmware to ensure the right charging routines are implemented, proper runtime calculations are made, and accurate reporting of state of charge occurs. Always contact the manufacturer to determine which batteries are safe and compatible.

How do they differ in size and weight from lead-acid batteries?

In general, a lithium-ion battery system for a UPS will take up 50-80% less floor space and weigh 60-80% less than a comparable lead-acid system. This dramatic savings is due to the very high specific energy (energy density) typical of Li-ion batteries. The specific energy rating for lithium batteries available today range from 70 kWh/kg to as high as 260 kWh/kg with most being in the 120-200 range. By comparison, a typical lead acid battery is in the 30-50 kWh/kg range.

What is the cycle life of lithium-ion batteries?

Cycle life refers to the number of times a battery can expect to be fully discharged and recharged within a specified temperature range before it needs to be replaced. Once a battery's capacity at full charge reaches 60-80%, then that battery becomes non-useable for the application and should be replaced. For a traditional sealed lead-acid battery, the cycle life is between 200 and 400 cycles. A typical Lithium-ion battery used for UPS applications can survive for more than 1000 cycles. The

number depends on several factors including the specific chemistry employed in the design. Some Li-ion batteries today can do over 5,000 cycles.

What type of maintenance is required?

Lithium-ion batteries have very low maintenance requirements. There is no fluid level to measure and maintain (nor is there for valve-regulated, lead acid batteries). There is neither battery “memory” to be concerned about nor any need to periodically cycle the batteries to calibrate their runtime. And their long life span of 10 or more years reduces the need to have to replace them over the course of the UPS’s period of use. By the time the batteries need replaced, it is likely time to replace the UPS as well. The included battery management system (BMS) automatically collects and reports all the required data to accurately understand the battery system’s health and status which further reduces maintenance burdens.

Do I need to cool lithium-ion batteries used in UPSs?

Both lead acid and lithium-ion batteries will see a degradation in cycle life as the temperature rises. However, in general, li-ion service life is less affected by higher temperatures than lead acid. Many of the li-ion batteries being used in UPSs are designed for higher average temperatures (e.g., 40°C/104°F) and are capable of reaching the specified service life at those higher temperatures.

For both types of batteries, the capacity (amp-hours or “Ah”) actually increases as the ambient temperature goes up. However, higher temperatures could limit the available runtime of that battery even within the acceptable operating range specified by the manufacturer. This is rare and depends on several factors including the discharge rate, the thermal-handling capabilities of the specific design of the battery in question, and, of course, the temperature. Particularly at higher discharge rates, the battery could reach its thermal limit and shut down before its available capacity is actually used. For the majority of li-ion UPS applications, no supplemental cooling is required to maintain cycle life, however, keeping the batteries cooler (e.g. 25°C/77°F) can help ensure the full available runtime is realized.

How should they be stored?

Storage in a cool place slows the aging process of lithium-ion (and other chemistries). Manufacturers recommend storage temperatures of 15°C (59°F). In addition, the battery should be partially charged before placing in storage. Many manufacturers recommend a 20%-40% state of charge. (Source: Samsung SDI & Battery University)

Are they hot-swappable?

No, lithium-ion batteries are, by nature, not hot-swappable. This is due to their high sensitivity to being over and under charged (low impedance).

Are Li-ion batteries “greener” than lead acid batteries?

There are many different ways you could consider a product to be more environmentally friendly or not than another. Li-ion batteries do not contain hazardous materials while lead-acid batteries do (i.e., lead). Both battery types are recyclable; however, at present it is much easier in most regions of the world to recycle lead acid than larger format li-ion batteries used in UPSs and electric vehicles. For a

complete picture of environmental impact, however, consider the entire carbon footprint over the course of the battery lifecycle. Carbon use accumulates throughout the product lifecycle:

- Raw material extraction
- Energy to produce and transport
- Operating energy to keep batteries charged and cooled
- Recyclability and impact on the earth when it is time to dispose

Previous analysis⁴ has shown that the operating losses (i.e., the energy used to keep the batteries charged) are, by far, the dominant driver of the carbon footprint of a UPS and its battery system over a 10 year life cycle. However, there is not a large difference in operating losses between the two systems. Which one edges out the other depends on the actual use case.

Lithium-ion batteries do require less energy to keep them charged than lead acid. The charge cycle is 90% efficient for a lithium-ion battery vs. 80-85% for a lead acid battery. Additionally, lead acid batteries self-discharge at a higher rate than Lithium-ion. These efficiency gains, however, are offset by the need for Li-ion to have a battery management system (BMS) to protect against short circuits and overcharging. This monitoring system consumes energy. So the total operating losses are very similar between the two.

With the dominant factor for determining a 10-15 year carbon footprint basically a wash, one must look to the other factors. Given that lithium-ion batteries containing landfill-safe materials are recyclable, and because their lifespan is 2-3 times longer than lead acid batteries, it can be argued that lithium-ion batteries are “greener”. However, note that the recycling rate of lead from lead-acid batteries is 99%⁵ with over 90% of the batteries being collected⁶ (in North America...similar rates occur in Europe and Japan). The state of recycling for lithium-ion batteries, particularly the larger format ones (such as those used in electric vehicles and data center UPSs), is much less mature, however. Read the next FAQ to learn more.

Are they recyclable?

Yes, they are recyclable. And there are many recyclers who will take smaller lithium-ion batteries. However, at the time of this writing, most smaller format batteries are simply collected and then sent off for shredding and incineration where some of the materials used in the production might be recovered. Much of the material ends up in landfills. From a purely financial viewpoint, recycling lithium-ion batteries to recover the very small amount of lithium metal and other more common, but less valuable metals (aluminum, nickel, etc) is not worth the effort. Research is on-going to improve the recycling economics and governments are beginning to encourage, incent, or outright require the collection and proper recycling of the batteries.

Recycling larger format lithium-ion batteries (i.e., the kind of packs used for electric vehicles and data center UPSs) is more complicated. Given their size, the safety hazards involved in handling, incinerating, and separating out the constituent parts are greater. These large batteries have PCB boards and associated circuitry that

⁴ [WP209, Lifecycle Carbon Footprint Analysis of Batteries vs. Flywheels](#)

⁵ http://c.ymcdn.com/sites/batterycouncil.org/resource/resmgr/Press_Releases/Recycling_Study_Press_Release.pdf (last accessed on 2/26/16)

⁶ <http://www.qsbattery.com/content/recycling> (last accessed on 2/26/16)

requires a lot of manual processing to disassemble them and prep them for shredding. At the time of this writing, there are few companies who are able to recycle and process these large lithium-ion battery systems. The market is immature. Few of these batteries have reached their end of life, so the demand has been very small. However, given the anticipated growth of electric vehicles and the use of these batteries in UPS and other applications, recycling vendors are beginning to come online who can handle these larger formats.

Schneider Electric believes that for batteries purchased today for UPSs, there will be many more recycling options for the larger format lithium-ion cells by the time they are in need of replacement 10-15 years from now. Contact the vendor for specific information on the options available today for the battery in question.

Are there any special considerations for transporting them?

Yes, regulations vary by locale, but a good guide for understanding air shipment restrictions and requirements is the International Air Transport Association (IATA) and their “Dangerous Goods Regulation” (DGR)⁷ which describes air shipment mandates by size, weight, and number. The transport of lithium-based batteries is divided into non-Class 9 hazardous material and Class 9 hazardous material⁸. Non-Class 9 involves the shipment of smaller, low volume quantities while Class 9 involves the shipment of larger numbers and sizes of batteries. Labeling, packaging, and any unique handling requirements are described for each class.

Remember that batteries of all types face certain requirements and restrictions. Batteries shipped inside equipment typically have to be shipped disconnected, for example. While all of this may seem onerous to the end user or reseller, it is the manufacturer of the system that typically assumes the burden and responsibility for ensuring compliance through proper design, labeling, user documentation, and packaging.

Do I need a battery management system when using Li-ion?

Yes, and it is already included in every lithium-ion battery system. As already stated, lithium-ion batteries are very sensitive to overcharging, shorts, and being discharged too far. The management system constantly monitors each battery cell and controls the charging system to ensure these conditions do not occur or do not result in damage or overheating.

How does the recharge time compare to lead acid batteries?

The battery charger is typically controlled and contained within the UPS. In this case, the time to reach an 80% state of charge (SOC) is more or less the same. The lithium battery has a slightly better charge efficiency, so it will reach that level slightly sooner. But to go from 80% to 100% state of charge, the lithium-ion battery is far better. A li-ion battery will reach a 100% SOC in 30 minutes to an hour assuming, of course, that the UPS is capable of supplying the power to charge at this rate. Regardless, it will be 5-10 hours less than charging a lead acid battery system to 100%.

⁷ <http://www.iata.org/publications/dgr/Pages/index.aspx> (last accessed on 1/19/2016)

⁸ http://batteryuniversity.com/learn/article/shipping_lithium_based_batteries_by_air (last accessed on 2/26/16)

Conclusion

Lithium-ion battery technology has evolved so that they are now financially viable for new applications and are safe to use in larger applications such as electric cars and data center UPSs. Their unique chemistries and cell packaging yield advantages over more traditional battery alternatives. In the case of UPS applications, li-ion batteries are smaller, lighter, recharge faster, and have double or more the calendar life span than lead acid batteries, the dominant energy storage technology used today in battery backups. Li-ion is arguably a more environmentally friendly solution. And, perhaps surprisingly given the higher acquisition cost, has a lower total cost of ownership (TCO). This paper serves to answer some of the fundamental questions new users are expected to have. And, in doing so, help UPS users and specifiers make a rational choice when evaluating energy storage technologies.

About the author

Patrick Donovan is a Senior Research Analyst for the Data Center Science Center at Schneider Electric. He has over 20 years of experience developing and supporting critical power and cooling systems for Schneider Electric's IT Business unit including several award-winning power protection, efficiency and availability solutions. An author of numerous white papers, industry articles, and technology assessments, Patrick's research on data center physical infrastructure technologies and markets offers guidance and advice on best practices for planning, designing, and operation of data center facilities.

Martin Zacho is a Senior Engineer in Energy Storage Technologies at Schneider Electric, Secure Power, IT Business. He holds a Bachelor degree in Computer System Engineering from University of Southern Denmark. He started out at Schneider Electric in 2000 (American Power Conversion at the time) working with Hydrogen Fuel Cells. After 3 years he switched to firmware control and FPGA programming for the Symmetra line products. He has been involved in all aspects of energy storage technologies since 2008 with special focus on energy storage for large 3 phase UPS's. The relevant technologies being lead acid batteries, ultra-capacitors, flywheels and various lithium based technologies. He is a member of The Danish Standardization Committee regarding energy storage.



 [Lifecycle Carbon Footprint Analysis of Batteries vs. Flywheels](#)
White Paper 209

 [Battery Technology for Data Centers: VRLA vs. Li-ion](#)
White Paper 229

 [Browse all white papers](#)
whitepapers.apc.com

 [Lithium-ion vs. VRLA Battery Comparison Calculator](#)
TradeOff Tool 18

 [Browse all TradeOff Tools™](#)
tools.apc.com

Contact us

For feedback and comments about the content of this white paper:

Data Center Science Center
dcsc@schneider-electric.com

If you are a customer and have questions specific to your data center project:

Contact your Schneider Electric representative at
www.apc.com/support/contact/index.cfm